

1. Match the vector valued function with the appropriate graph of the function.

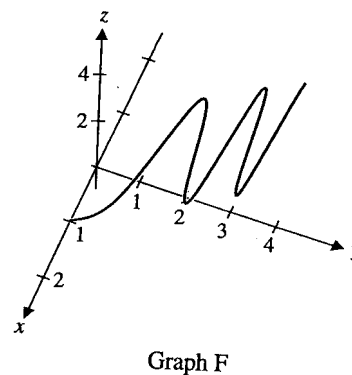
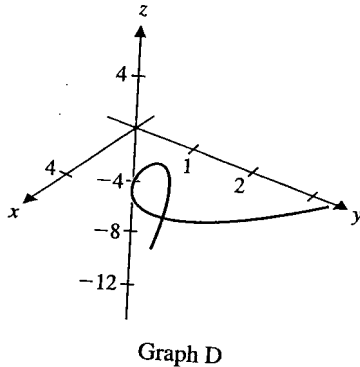
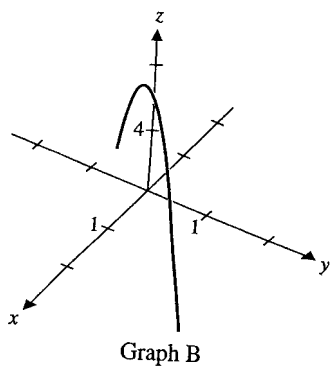
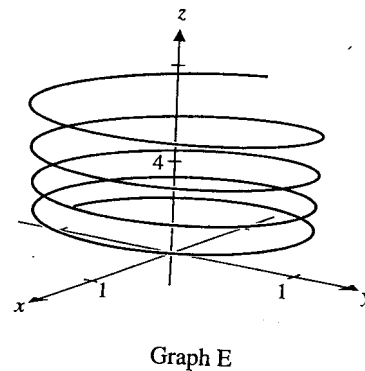
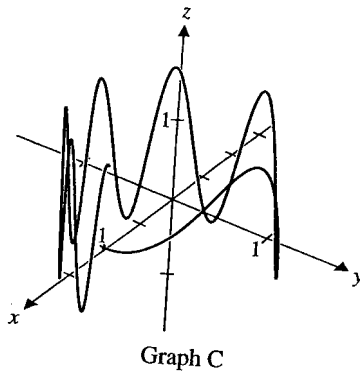
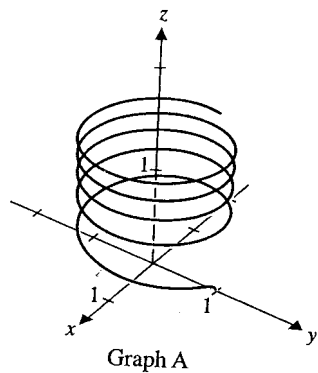

(a) $\mathbf{r}(t) = \langle \cos t^2, t, t \rangle$

(b) $\mathbf{r}(t) = \langle \cos t, \sin t, \sin t^2 \rangle$

(c) $\mathbf{r}(t) = \langle \sin 16\sqrt{t}, \cos 16\sqrt{t}, t \rangle$

(d) $\mathbf{r}(t) = \langle \sin t^2, \cos t^2, t \rangle$

(e) $\mathbf{r}(t) = \langle t, t, 6 - 4t^2 \rangle$

(f) $\mathbf{r}(t) = \langle t^3 - t, 0.5t^2, 2t - 4 \rangle$

2. Sketch the function $\mathbf{r}(t) = \langle t, t^2 + 1, 2 \rangle$

3. Find all values of t such that $\mathbf{r}(t)$ and $\mathbf{r}'(t)$ are perpendicular if $\mathbf{r}(t) = \langle t^2, t, t^2 - 5 \rangle$

4. Find the velocity and position of an object at any time t , given that its acceleration is $\mathbf{a}(t) = \langle 6t, 12t + 2, e^t \rangle$ and its initial velocity is $\mathbf{v}(0) = \langle 2, 0, 1 \rangle$ and its initial position is $\mathbf{r}(0) = \langle 0, 3, 5 \rangle$.

5. For the following position vector $\mathbf{r}(t) = \langle t, -t^2 + 8 \rangle$

a. Sketch the curve of motion.

b. Plot the vectors $\mathbf{r}(1)$, $\mathbf{v}(1)$ and $\mathbf{a}(1)$ on the sketch.

6. Find the arc length along the path of $\mathbf{r}(t) = \langle e^{2t}, \sin(t), t \rangle$ for $-\pi \leq t \leq \pi$.

7. A baseball pitcher throws a pitch horizontally from a height of 6 feet with an initial speed of 130 feet per second directly over home plate. Find a vector function describing the position of the ball t seconds after release. If home plate is 60 feet away, how high is the ball when it crosses home plate?

8. A football punt is launched at an angle of 50° with an initial speed of 50 meters per second. Assuming the punt is launched from ground level, compute the hang time (the amount of time in the air) for the punt.

OTHER VIEW OF SPACE CURVES

A.

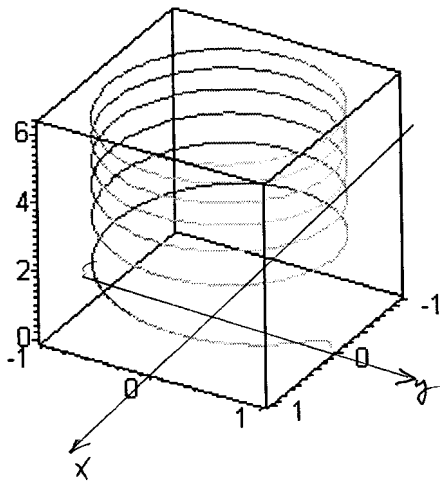

D.

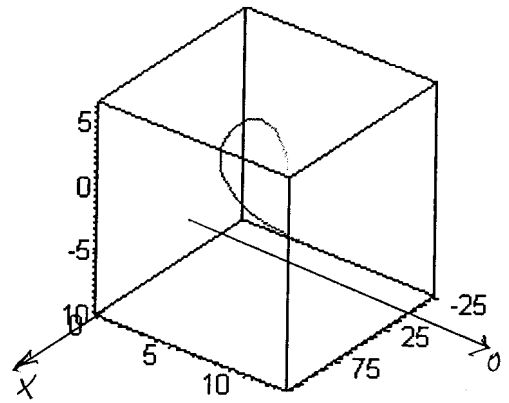

B.

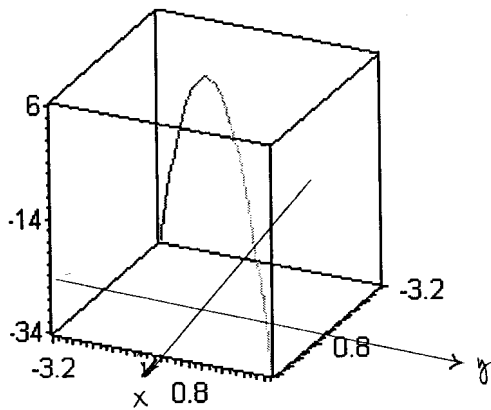

E.

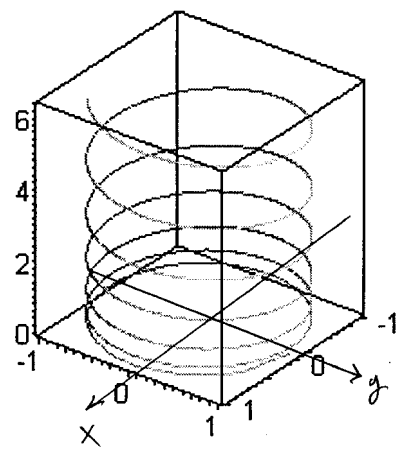

C.

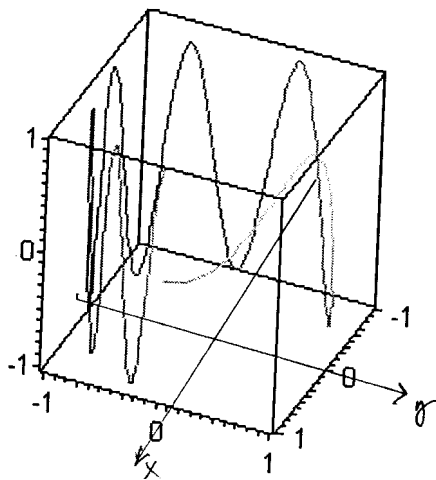

F.

