

# A Java based One Wire Distributed Earthbox Watering System

## 1.0 Introduction

Some time ago I became interested in Earthboxes. The Earthbox is the trade name for a commercially available gardening box product from the Earthbox Company. These boxes have grown in popularity and recently have been adopted by the United Nations as a means of increasing food production Worldwide. They are an ideal choice for folks like me that have limited sun access (I live at the edge of a forest). They are also idea for other folks who want the convenience of a productive garden without devoting a large amount of time and real estate (garden area). The Earthbox Company has patented their box concept. These boxes are self contained and engineered with soil containers, internal water reservoir and fertilizer reserves to yield very heartily and productive vegetable gardens from a modest start of planting two-inch seedlings. Newer Earthbox designs are also be equipped with casters for mobility and an integral staking system. A representative cut away view of the Earth box is shown.

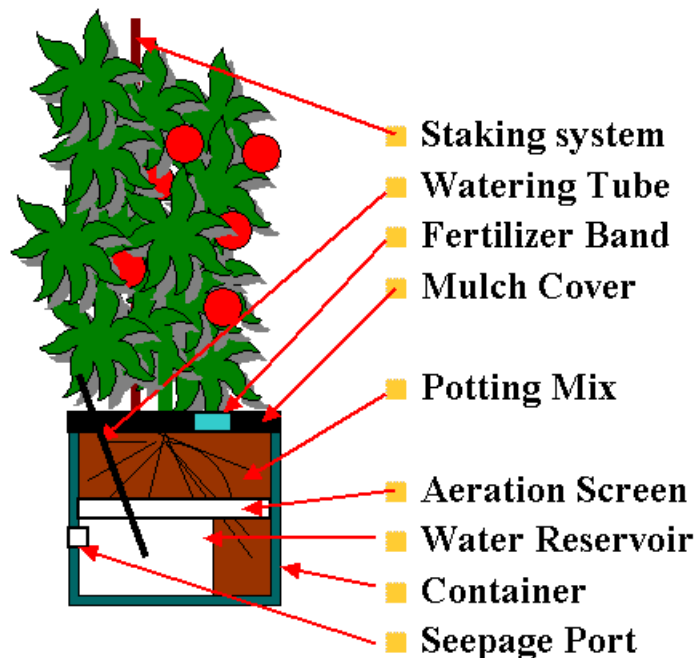

Figure 1 Cut Away illustration of Earthbox technology.

When we started using Earthboxes we were amazed with the amount of tomatoes and eggplants harvested from just four plants (two plants per box in this case). The boxes do require regular watering to sustain the internal reservoir levels as the plant uses up the water supply. This is pretty infrequent to start with, when the plant is little, but as it matures and bears vegetables the watering is extremely important and water levels must be sustained at least once a day to yield reasonable sized fruit. The internal water reservoir makes contact with the soil just above it and allows the soil under plant respiration action to wick up water from the reservoir as needed. To facilitate the watering process, Earthbox has a watering tube located at the size of the box. This watering tube empties into the internal reservoir. During watering, as the internal reservoir gets filled to capacity there is a seepage hole built into the side of the box that starts to release water, thereby insuring that there is no over watering. Again, this is good engineering from the folks at Earthbox Company. For me my manual process for watering was to slip a garden hose into the watering tube of each Earthbox, let it fill, and then note when the seepage hole releases water and then move onto the next box and repeat the process.

My ambition grew since my early start with just two boxes to today's six Earthboxes. (We do like our fresh vegetables!). Given these circumstances watering all six boxes daily can become a chore. Here's where I opted to develop an automatic distributed watering system for my boxes that is expandable (way beyond six boxes) and will sustain all the watering reservoir levels based upon a programmable watering cycle time that I can set. I also wanted then to be able to monitor on a per box basis amount of time the system spends watering each box. This monitor would give me a good indication that the Earthbox is functioning and the plants are growing (despite just a visual check on plant size). The system would need to be distributed to allow me to judiciously situate the boxes where they could benefit from maximum sun exposure and not "crowd up" anyone area around the house. I envisioned a totally hands-off gardening system where in the end all that is required is just to set up the boxes with plants, fertilizer, and soil, and then eventually harvest.

Luckily the watering technology exists: it is most prevalent in lawn irrigation systems. Garden hose is cheap and water distribution is easily accomplished with lengths of hose and available garden hose manifold distribution fixtures. Watering control is easily accomplished through the use of inexpensive lawn watering solenoid-controlled valves. These valves can connect to garden hose using PVC pipe and the proper hose fittings. To control these valves and monitor water levels I opted to use MAXIM/DALLAS One Wire technology. I just completed a larger development recently using this technology and was impressed by its simplicity and reliability. Using One Wire would allow all valve controls and watering levels for each remote box to be uniquely addressed, monitored and controlled from a single location. One Wire technology, in general, would easily support a very large distribution of Earthboxes. Given the right One Wire driver, cable type and terminations, total cable lengths of 300 meters are possible and populations of over a 100 hundred one wire devices (that about 50 Earthboxes total in my scheme).

The other key element was choice of Microcontroller. I wanted a Microcontroller that had JAVA language capability. Again I just completed a larger development recently using JAVA and was impressed with the object oriented languages its reuse capability and extensibility to larger platforms if necessary. Microcontrollers are available in all

shapes and sizes, but there are limitations on what is easily available for embedded Java. I chose the Parallax Javelin stamp. It is a flash re-programmable single board computer (physically about the size of a postage stamp) with 32K RAM/program memory, support for a host of virtual peripherals: UART, timer, ADC, DAC, bit, ports, buttons. The Javelin is programmable in a SUN Java Language subset using Parallax IDE and has debug capabilities and Java library classes to easily deal with one wire and embedded Java applications in general.

## 2.0 Concept Overview

A conceptual system block diagram of the system is shown. The approximate distribution of each Earthbox is about 100 feet maximum from the Javelin Based Controller Box.

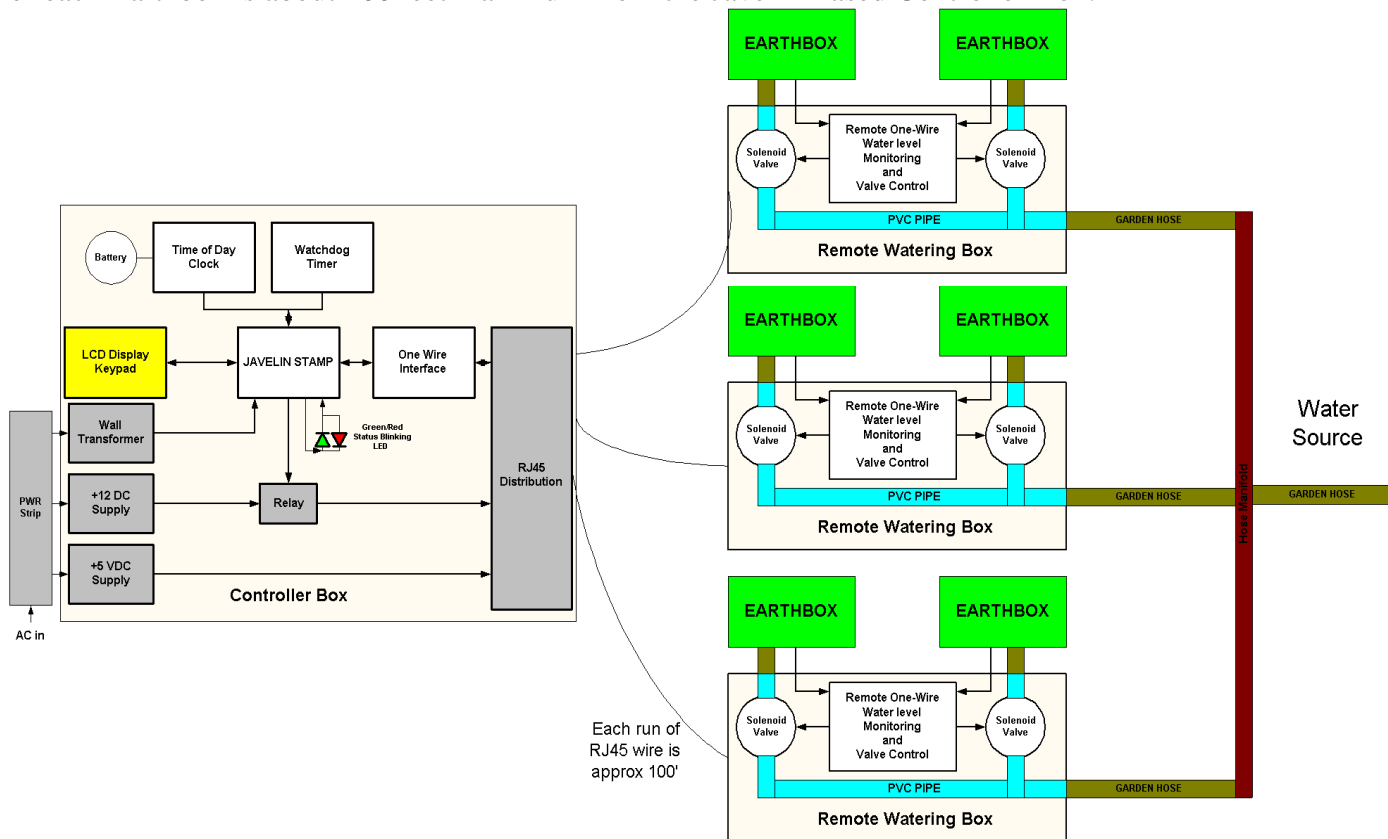

**Figure 2 Conceptual Block Diagram of Entire Watering System showing Controller Box and the Remote Watering Boxes with associated Earthboxes**

The Controller Box house contains the Javelin Controller, the One Wire interface, a One Wire distribution hub, system power, Time of day chip, Watchdog timer, Solid State relay for solenoid power on/off, LCD display with Keypad for operator detail status/control and a dual color LED for general status indication. The entire assembly is housed in a clear box assembly as shown in figure 3. This box is not waterproof, however, it can remain outdoors under the shelter of a porch for easier connection to the remote Earthboxes.



**Figure 3 Photo of Controller Box. All components are visible. In center is LCD display and Keypad; Javelin Stamp is located on the right. RJ45 connections are to rear of box. A dual color leds flashes to indicate overall status of the system. It is green indicating proper operation (other wise it would flash red)**

The second part of the system is the remote watering boxes (see figure 4). Each remote box is connected to the controller box for control/status reporting and power via a modified RJ45 cable connector scheme. The same clear box type used for the controller is again used for the remote box; however, within the larger remote box a small plastic waterproof box is incorporated for the One Wire valve control and water sensing electronics. Also within this larger box are the solenoid irrigation valves and PVC manifold construction for water flow to each Earthbox. For each manifold a garden hose must be connected for water supply. To facilitate this a 1/2" to garden hose adapter is mounted to the water entry for each manifold.



**Figure 4** Photo of single Remote Box is shown connected to Earthboxes. The Remote box supplies water to each Earthbox through the black hoses. The remote box contains an internal water proof box for the electronics as well as the PVC manifold and valves. The water sensor wires are the white wires coupled to the hose and feeding back to the remote box.

An internal view of the Remote box is shown where the particulars and its layout of all components is illustrated. See figure 5. Here the remote box cover is opened and a explicit view of the construction and location of the remote electronics box, hose, valves, PVC manifold, hose and feeder connections, along with sensor wires within the remote box is revealed. The solenoid relay of choice was the RJ ¾” in-line valve from Lawn Genie—easily available from Hardware Store Supplies. To weight down the remote box I selected crushed white rock. It appears in figure 5 “surrounding” all the other components.

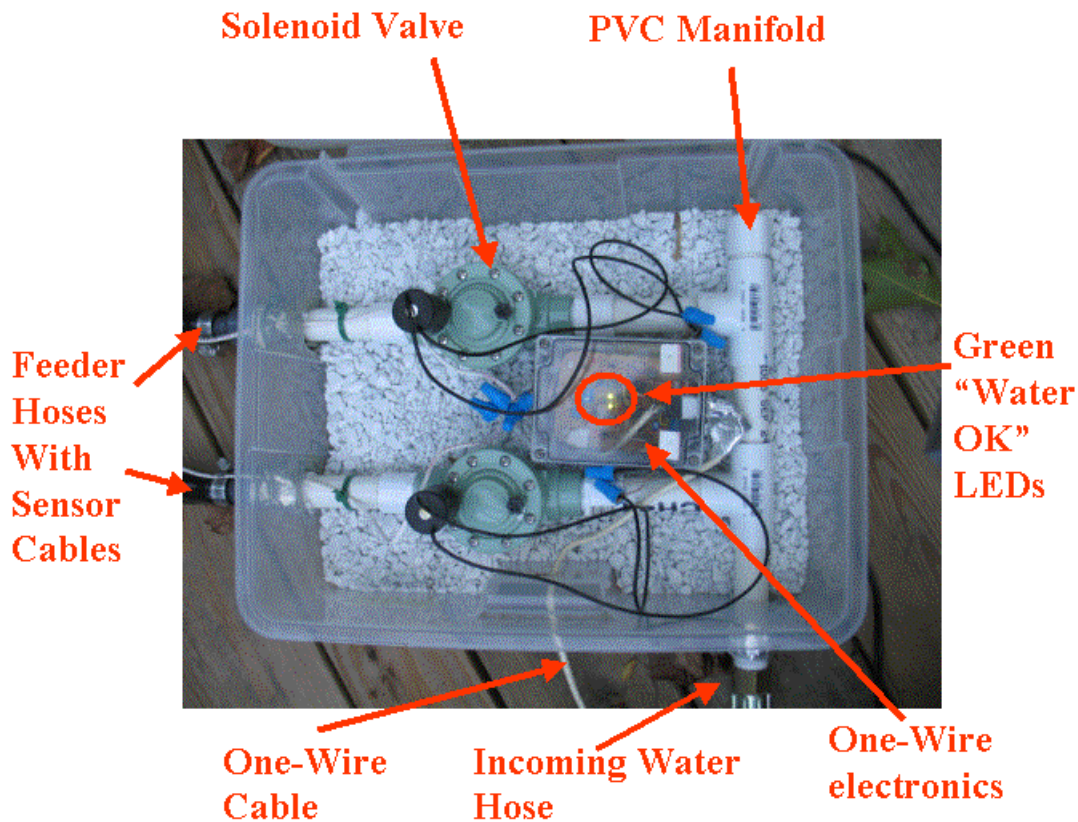
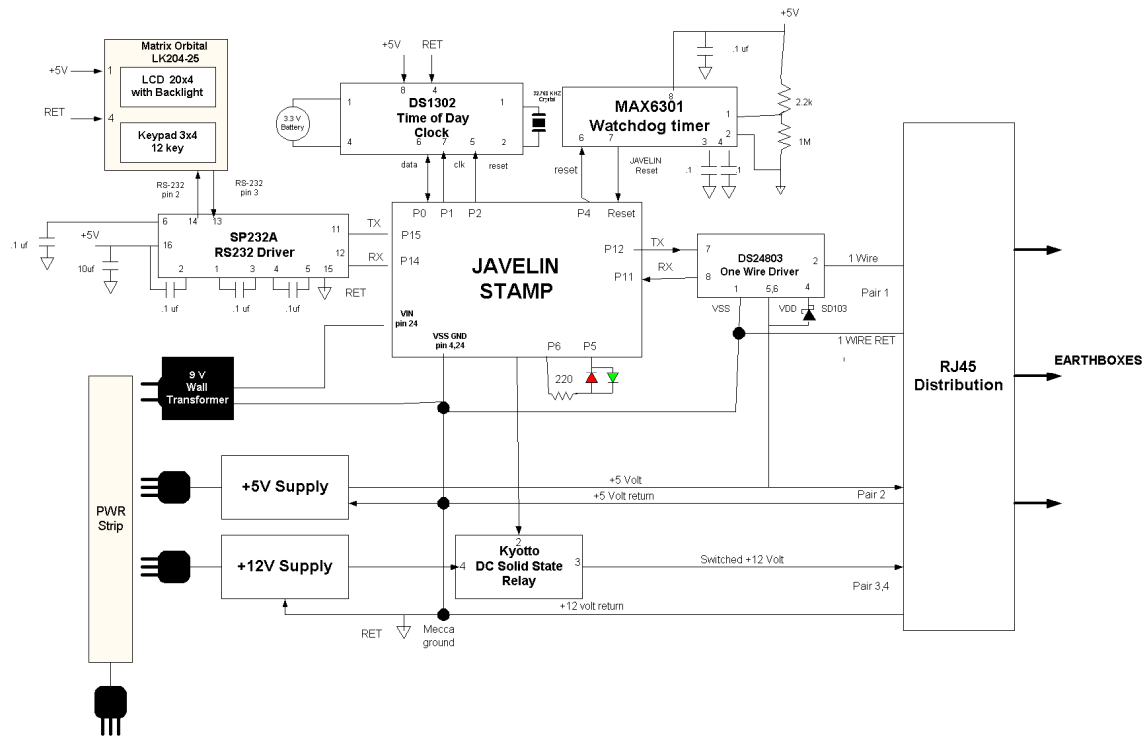

**Figure 5** Photo of the remote box opened. The construction and placement of the major internal components of Remote Box is clearly depicted.

With this entire scheme the single controller can monitor the water level of each individual earth box and then with this knowledge control the watering of each Earthbox through its particular solenoid water valve to achieve the desired water level. Each valve and each water sensor is uniquely addressed using One-Wire. The watering scheme can be implemented automatically or manually on-demand –it is just a matter of software. For the system, as deployed, both automatic and manual schemes are used. In the automatic mode the user can set the frequency of the watering cycles (from 1 hour up to every 16 hours) and the maximum valve/watering on time (for 1 minute to up to 20 minutes) for individual watering requirements. The maximum on time is a preventive measure to insure that each valve does not stay on too long to achieve the desired water level—especially if water is shut off or is not connected to the remote box. The controller logs the accumulated watering times for each Earthbox as well as notes if a maximum on time has been exceeded. If a maximum on-time has been exceeded the controller will bypass this valve for the next watering cycle and periodically flash the dual color LED as red to alert the user, otherwise if all conditions are satisfied the LED will blink green. This watering scheme as designed is inherently flexible and expandable.

### **3.0 Hardware Overview**

A more detailed representation of the hardware for the Controller Box is shown in figure 6. The Javelin Stamp is shown with its associated pin out including power and peripheral connections. Power is from a number of sources: Wall Transformer to Stamp, a +5VDC power supply to all remote box electronics, and finally +12 VDC power source and return to valves solenoids. Individual returns for the +5VDC and +12 VDC were required to insure noise free operation. The +12VDC is switched using a KYOTTO Solid State Relay. It was realized that +12VDC should only be applied once it has been decided to switch the solenoid relay. +12V @ .500 ma is sufficient. The wall transformer (+9 VDC) is used with a STAMP prototype board and its internal regulator (LM2940) regulates to the +5VDC required by the Stamp. Because of the larger requirement for +5 VDC by the Earthbox remote box electronics (versus what the Stamp prototype board could deliver) a separate +5VDC supply was used. Both the +5VDC and +12VDC power is distributed to the Earthboxes via pair 2 and pairs 3,4 of the RJ45 connection respectively. Two pairs were assigned to the +12V because of the larger current requirement. In addition, all ground returns are separated and connected to a "Mecca ground" within the Controller Box to minimize noise. The remaining RJ45 pair is connected to the One-Wire electronics. The One-Wire electronics driver (DS2408 One-Wire Driver) hardware and software is fully specified in app note 1a "Getting started with One-Wire" for use with Javelin by Parallax. The Javelin Stamp reports total system condition through the use of a Red/Green Led blinking. More detailed status and control is available to the user through the Orbital Matrix LK 204-25 LCD display and its associated keypad. To support this LCD/Keypad interface an RS-232 interface to the Javelin Stamp Virtual Peripheral Uart is required. This interface is physically accomplished with the use of the SP232A RS232 driver chip. The controller maintains time of day and its watering cycles as well as elapsed time using the DS1302 TOD chip. This chip is battery backed up using a 3.3 Volt lithium cell. Again this interface is well supported by Parallax in app note 2 "Getting started with the DS1302". With this app note the Javelin Stamp Library can incorporate a DS1302 object for application reuse. Finally a WATCHDOG timer chip the MAXIM 6301 is used. Watchdogs are an important part of insuring reliability within embedded designs by providing an external (non-software) reset to the Controller on a periodic basis. If the controller is fully functional and operating within its code sequence a provision is made within each code segment to provide a "reset" to this watchdog timer prior to its own timeout (whereby it sends a reset to the controller). Watchdogs are generally recognized in the industry as a method to insure reliable operation of embedded controller. In this case a 6 second Watchdog time out is used.



**Figure 6 Schematic representation of the overall Controller Box. In center is the JAVELIN Stamp connected to all its peripherals. Exiting the box are RJ45 cables through the RJ45 distribution to associated remotes and their Earthboxes.**

The remote electronics is based upon the One Wire DS2405 and DS2406 switches. Both switches have open drain PIO pin that can be controlled remotely. The DS2406 also has integral EEPROM memory (not used in this design). The DS2405 is used with the valves and the DS2406 is used for the water sense level. I choose the DS2406 for water level sensing because its command structure allows for direct reading of PIO pin state. The DS2405 can only be read once the command to change it has been issued. It is an oddity, however it is also much less expensive than the DS2406. So in a round about way you need to command the DS2405 switch in order to access the PIO state and then possibly command it again to change it to its desired state. I choose to use these for the valve control. Figure 6 shows a schematic for dual DS2405 and DS2406 pairs used for remote box and associated two Earthboxes. The DS2405 has a 1K pull-up to its PIO pin which drives an 2N222A for a red LED on indication for the valve as well a control input to a MOSFET used to control the solenoid for the valve. The DS2406 is used to read the input from the water sensor. This sensor is simply an open base through 10K-1M to ground to a 2N222A transistor. Both the base and +5VDC are wired internal to the Earthbox to indicate proper water level in the Earthbox. When the water touches both leads the transistor is saturated and this condition is read by the DS2406. In addition a PNP transistor with GREEN led is used to visually indicate the water condition right at the remote box.

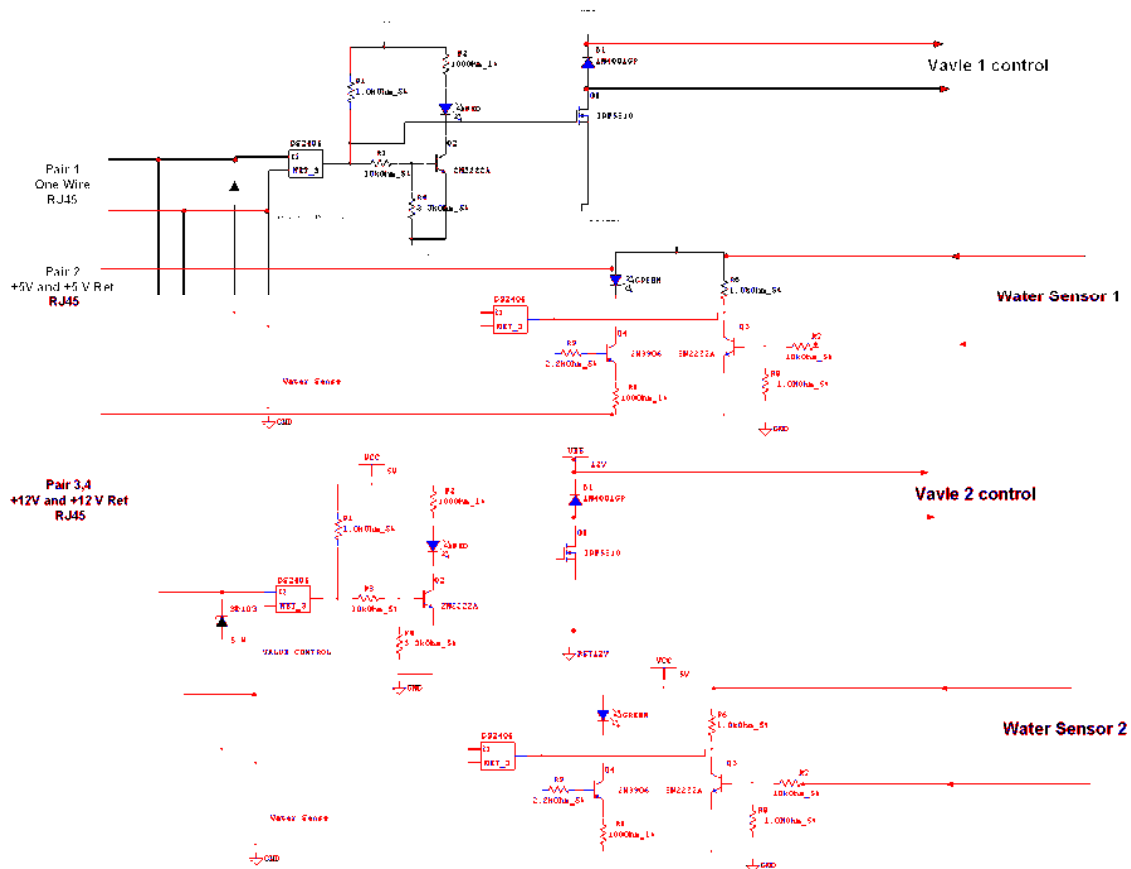

**Figure 7 Schematic Representation of the Remote Box electronics. The electronics is duplicated for each Earthbox water control and Sensor. The entire box connects to a single One-Wire interface. The DS2405 one wire device is used for valve control while the DS2406 one wire device is used for**

**watering sensing. A red led is connected to each valve control to indicate activity. A green led is connected to each water sensor to visually indicate water condition of the Earthbox.**

## **4.0 Software Overview**

The Embedded Java software is organized as shown in figure 7. The software is flash programmed into Javelin Stamp. There are five distinct classes Main Tester, display Key, DS2408 class, DS1302 class, and UART. The first two classes are new for this design, the remaining three are simply re-use from Javelin Stamp available libraries. The DS2408 class is used in an instance called oneWireBus. The supporting methods: reset (), message () and getBit () are all that is required to deal with both the DS2406 and DS2405 once their individual addresses and command sequences are known. Command sequences can be garnered from MAXIM/DALLAS spec sheets. Each device has a unique 64-bit address set at the factory. The addresses can be uncovered in one of two ways, write a simple Java routine using DS2408 class with your DS2408 adapter to pool the address of each part and display it for incorporation into the code, or use a Software utility downloadable from MAXIM/DALLAS web site known as iButton-TIMEX. This has a nice GUI for reading one wire reading/control. It works with a DS2408 RS-232 to One Wire Adapter that MAXIM/DALLAS also sells. The DS1302 class is used in an instance called "tinstance". Its associated methods are all that is required to set and read clock. The first custom class "displayKey" is instanced as simply "d". The function of this class is to build up the display contents, updates mode of operation, time, and status and on times for each valve. This class also reads the associated keypad for operator requested changes. Communication to the LCD and Keypad are essentially RS-232 and two instances of Parallax Uart class are used: one for transmit and the other for receive. The Main Tester class is where the main routine for initialization, and controller main processing loop. Main Tester has methods to control all individual DS2405's, and DS2406's. It processes recovered keystrokes from displayKey and takes appropriate action with display updates, mode changes, individual valve control etc. Main Tester also manages the Watchdog timer and the controller box Red/Greed Led indicator. In automatic mode the Main Tester functions in a continuous loop based state machine. An example for one case is shown in figure 8.

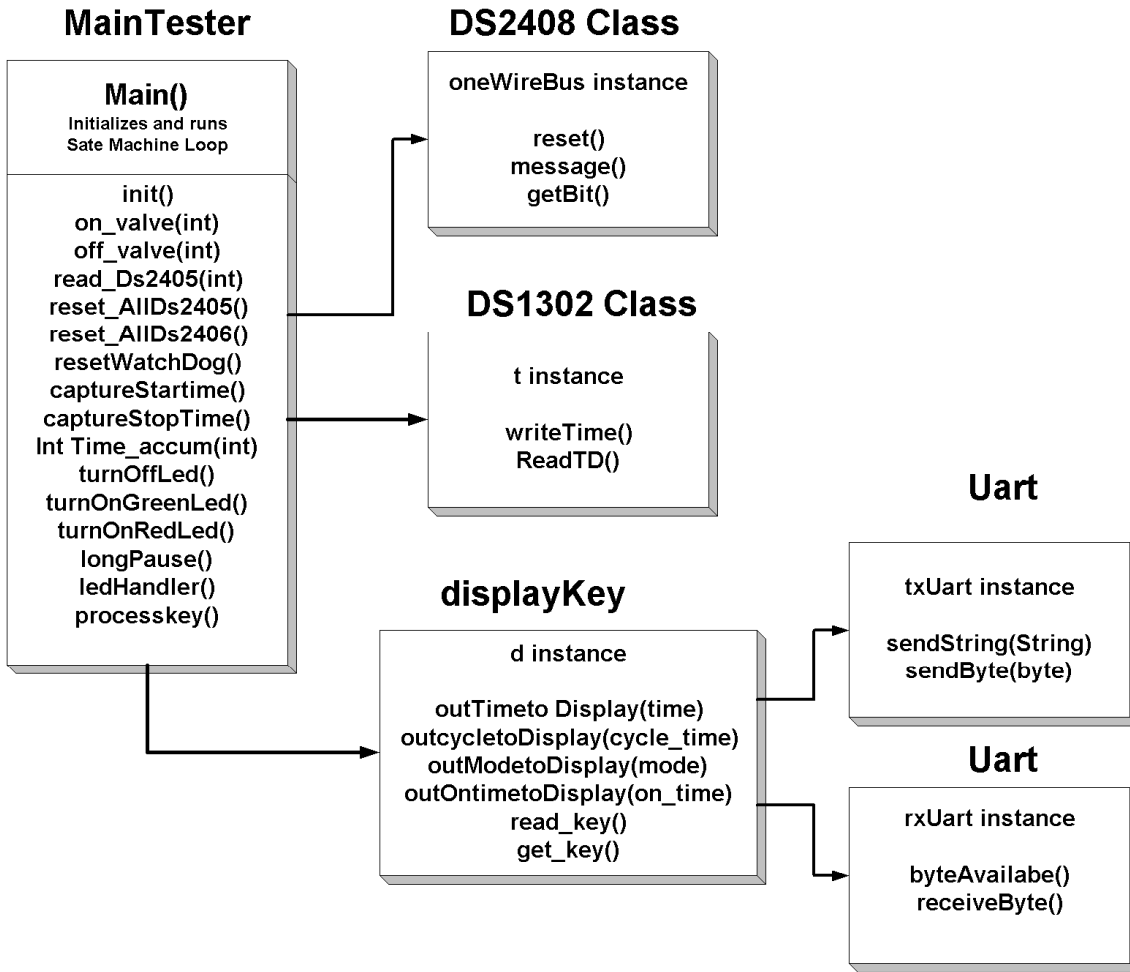

Figure 8 pictorial representations of the overall software structure and associated JAVA classes used by the Controller Box Javelin Stamp.

```

switch (state) {
//start of automatic process
case 1:
    address =switch1;
    valve_on = valve_state1;
//Test 1-if valve in error condition just bypass
    if (valve1_error){ state++; break; }
    water_ok =read_DS2406();
//Test 2-if water ok and valve is not on just move on to next state
    if (water_ok && !valve_on){state++;break;}
//Test 3-if valve is not on and water is low turn on valve start time
//return to same state
    if (!valve_on&& !water_ok)    {
        on_valve(1);
        captureStarttime();
        t_run =0;    //start timer
        //display valve on-stay in same state
        d.valve_Status (1,valve1_ontime,true,valve1_error);
        d.outTimetoDisplay(t.readTime(true)); break; }
//Test 4 -if valve is on and water is ok -turn off valve
// and display time or error
    if (valve_on && water_ok) {
        off_valve(1);
        captureStoptime();
        t_run= time_accum(0) ;    //t_run =diference of stop-start
        valve1_ontime= time_accum(valve1_ontime) ;
        if ( t_run> delta ) valve1_error =true;
        d.valve_Status (1,valve1_ontime,false,valve1_error);
        d.outTimetoDisplay(t.readTime(true));
        t_run =0;
        state++;
        break;
    }
}

```

Figure 9 Within the MAINTESTER class is a continuous loop State Machine. The code for one state within this loop is shown. Each individual valve and its associated water sensor represent a state. The system exits a state to the next state once all conditions are satisfied relative to the valve operation and water level.

## 5.0 Observations and Conclusions (lessons learned)

The system was rapidly prototyped using the Parallax Javelin stamp and its libraries/capabilities. This technology as well as One Wire was well suited for the Earthbox application. The system is working well during growing season and has really alleviated the watering chore associated with these boxes. In the future I intend to switch power to the water sensor prior to water measurement thereby minimizing any material build up on the sensor probe due to +5V DC voltage. Another alternative is to use an alternating source versus DC for the water sensor. Finally I would to explore the use of ZIGBEE in this application to further extent Earthbox range beyond one wire limitation. In the meantime I hope to be enjoying my vegetable bounty!

